

**17L  
4213**

## Nissan NP300 Navara D23, Md. 2016

EU-pedestrian protection bar 76 mm

EU-Personenschutzbügel 76 mm

Protection avant, homologuée CEE, 76 mm

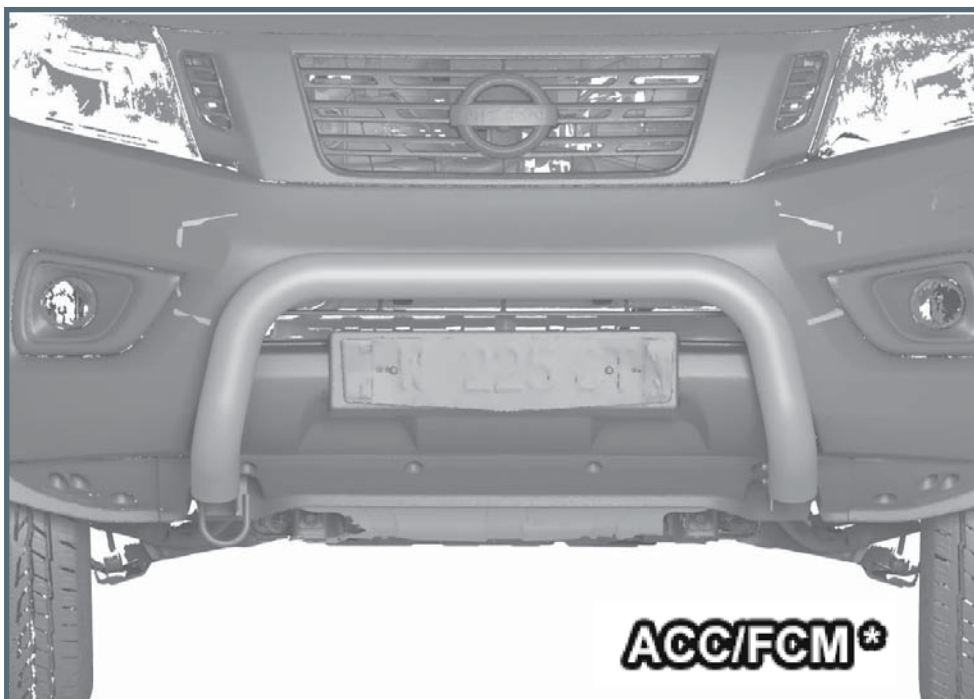

\*Compatible with Automatic Cruise Control /Forward Collision Mitigation  
Kompatibel mit Abstandsregeltempomat /Auffahrvermeidungs-oder warnsystem  
compatible avec radar de régulation de distance/ freinage autonome d'urgence



# ASSEMBLY INSTRUCTION

Montageanleitung • Instructions de montage

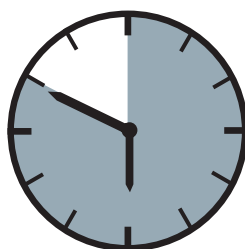

**50 Minuten**

### Artikel-Nr:

17L4213 stainless steel

17L5213 black steel

Revision 2: 18.05.2016



13  
17  
19

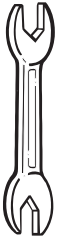

M8 (A2):  
21,4 Nm  
M8:  
25 Nm  
M10:  
50 Nm  
M12:  
87 Nm

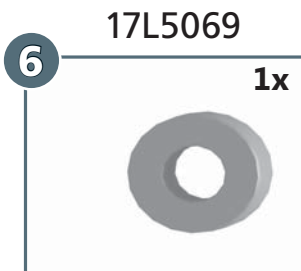
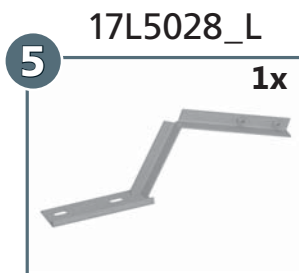
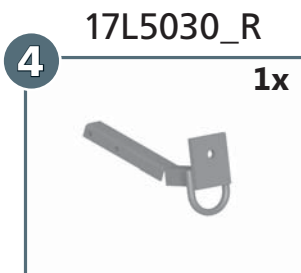
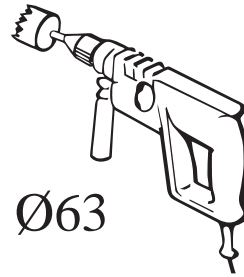
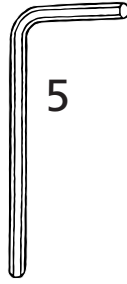
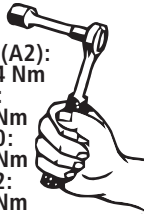

|          |  |                          |           |
|----------|--|--------------------------|-----------|
| <b>a</b> |  | M8x20; ähnl. ISO 7380 A2 | <b>4x</b> |
| <b>b</b> |  | M8; DIN 934 Zn           | <b>2x</b> |
| <b>c</b> |  | M8x25; DIN 933 A2        | <b>2x</b> |
| <b>d</b> |  | M12x55; DIN 933 Zn       | <b>1x</b> |
| <b>e</b> |  | M10; DIN 934 Zn          | <b>2x</b> |
| <b>f</b> |  | M12; DIN 934 Zn          | <b>1x</b> |
| <b>g</b> |  | Ø 8; DIN 127 Zn          | <b>2x</b> |
| <b>h</b> |  | Ø 8; DIN 127 A2          | <b>2x</b> |
| <b>i</b> |  | Ø 10; DIN 127 Zn         | <b>2x</b> |
| <b>j</b> |  | Ø 12; DIN 127 Zn         | <b>1x</b> |
| <b>k</b> |  | Ø 8,4; DIN 125 Zn        | <b>2x</b> |
| <b>l</b> |  | Ø 8,4; DIN 9021 A2       | <b>2x</b> |
| <b>m</b> |  | Ø 10,5; DIN 9021 Zn      | <b>2x</b> |
| <b>n</b> |  | Ø 13; DIN 9021 Zn        | <b>2x</b> |
| <b>o</b> |  | SW 13                    | <b>2x</b> |

